

SHIFT TRAY UNIT
(Machine Code: B313/B459)

1 OVERALL MACHINE INFORMATION

1.1 SPECIFICATIONS

| | |
|--------------------|-----------------------------------------------------------------------------------------------------------------------------------------------------|
| Paper Size: | Standard Size: A5 lengthwise to A3 HLT lengthwise to DLT Non-standard Size: Paper Width: 90 ~ 297 mm Paper Length: 148 ~ 432 mm |
| Paper Weight: | 60 ~ 105 g/m ² , 16 ~ 28 lbs. |
| Tray Capacity: | 125 sheets (80 g/m ² , 20 lbs.): B4 or larger 250 sheets (80 g/m², 20 lbs.): A4 or smaller |
| Power Source: | 5 VDC, 24 VDC (from the copier) |
| Power Consumption: | 17 W |
| Weight: | 1.1 kg |
| Size (W x D x H): | 530 mm x 410 mm x 120 mm |

1.2 COMPONENT LAYOUT

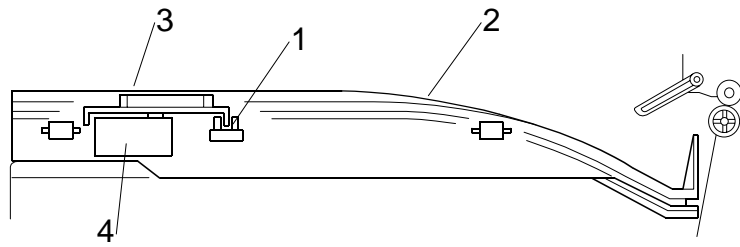

B459D101.WMF

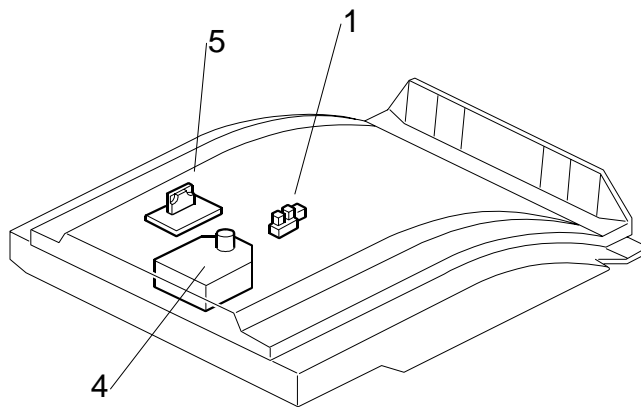

B459D102.WMF

1. Half Turn Sensor
2. Tray Cover
3. Slip Disc
4. Tray Motor
5. Driver PCB

2. DETAILED SECTION DESCRIPTIONS

2.1 BASIC OPERATION

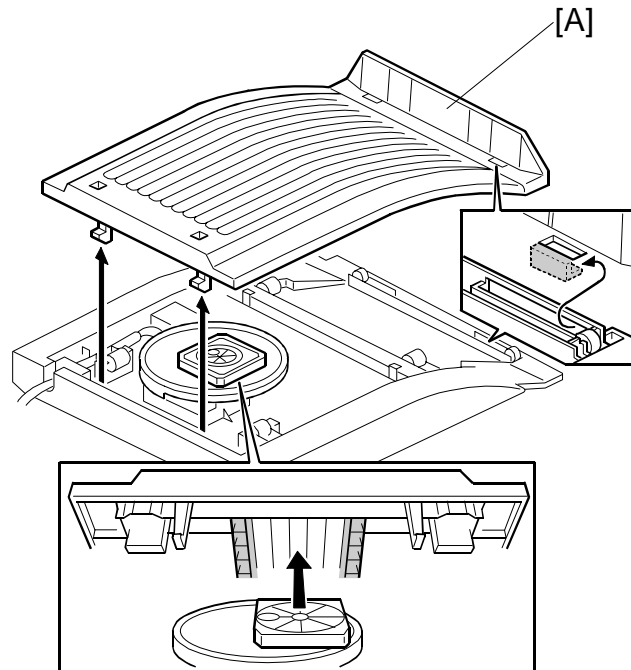

B459D500.WMF

The shift tray allows copies to be sorted into separate piles on one tray.

From the left-right movement of the tray cover [A], the piles of copies are offset into two positions, slightly overlapping one another.

2.2 PRIMARY MECHANISMS

2.2.1 TRAY SHIFT

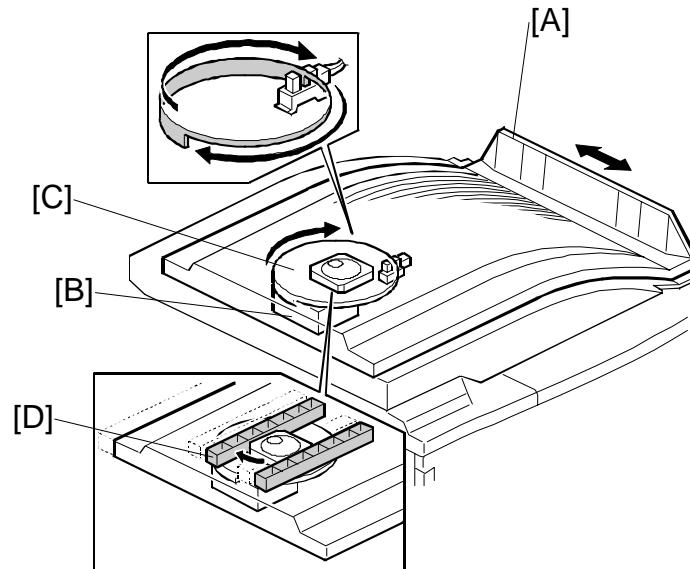

B459D103.WMF

As stated above, the shift tray cover [A] moves from left to right to create two possible positions for the copies to stack up. This motion is driven by the tray motor [B], which connects to the slip disc [C] via a small shaft. The shaft is connected at the rotational center of the disc. However, there is an off-centered white square attached to the top surface of the disc. When the tray cover is attached to the unit, this square fits into a groove [D] (approximately equal to its width) that runs lengthwise along the underside of the tray

When the motor is running, the disc rotation causes the off-centered white square to change position. Since the square only has freedom of movement along the groove [D], the only net motion of the tray is from left to right.

2.2.2 HALF TURN DETECTION

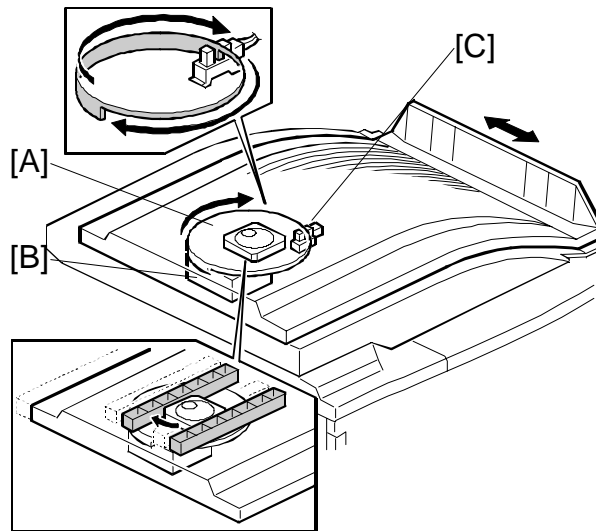

B459D103.WMF

Half turn detection is performed through a combination of two components: the slip disc [A] and half turn sensor [C].

The slip disc has a rim extending below the top surface. However, the rim only extends 180° around the disc. The half turn sensor is below the edge of the disc, opposite the tray motor. The sensor is positioned so that the rim of the disc passes between the LED and photo diode when the disc turns.

While the motor [B] is rotating the disc and moving the tray cover, the disc rim is not between the diode and LED. After the disc has turned its maximum 180°, the rim passes between these two parts and blocks the signal to the LED, stopping the motor. The tray stays in place until the motor is activated again to move the tray across to receive another copy of the original.

3. REPLACEMENT AND ADJUSTMENT

3.1 TRAY COVER REPLACEMENT

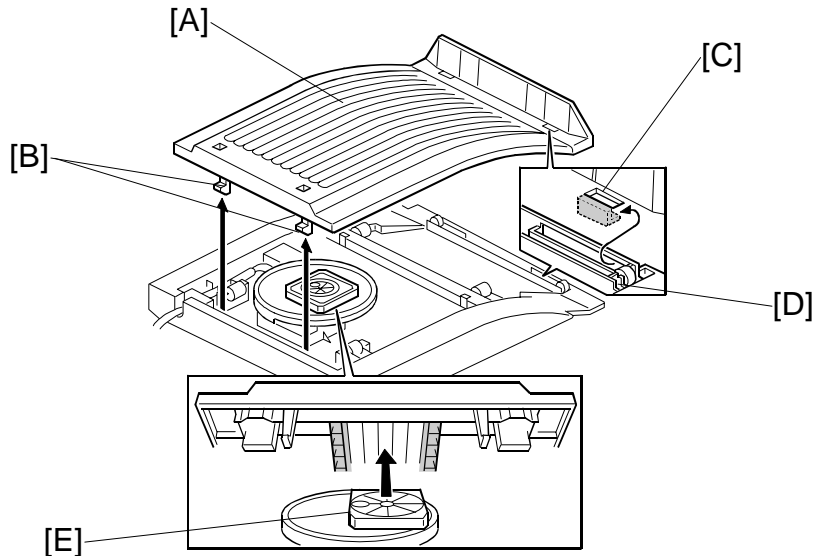

B459R101.WMF

3.1.1 TRAY COVER REMOVAL

1. Remove the tray cover [A] by pressing on the two pawls [B] on the left side of the cover.

3.1.2 TRAY COVER ATTACHMENT

NOTE: The right side of the tray cover should be attached first.

1. Fit the pawls [C] (just below the cover fin) around the thin bar [D] on the shift tray.
2. Align the square [E] so that it fits into the groove in the underside of the tray cover and does not interfere with the attachment of the cover.
3. Complete the attachment by inserting the left side pawls [B] into place.

3.2 TRAY MOTOR AND HALF TURN SENSOR REPLACEMENT

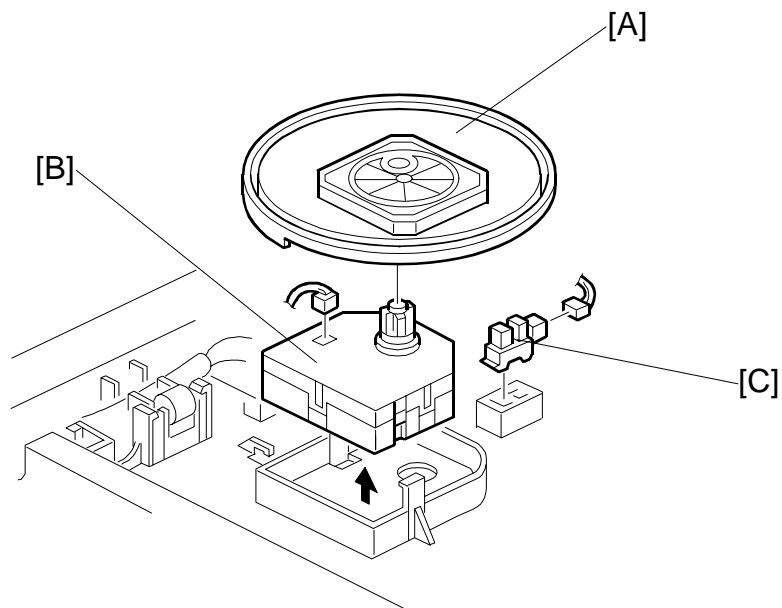

B459R102.WMF

3.2.1 REPLACING THE TRAY MOTOR

1. Remove the slip disc [A].
2. Remove the tray motor [B] from the motor holder (1 connector).

3.2.2 REPLACING THE HALF TURN SENSOR:

1. Remove the half turn sensor [C] (1 connector).